

Phoenix 20 Floor Scrubber Disc Traction Drive



Technical Specifications

Model *Phoenix 20 Traction Drive*

Model No. 3336075QP / PHX20TD / PHX20TDQP / PHX20TDQPG



Current (Max)	40 amps
Battery Capacity (Lead Acid)	140Ah @20 hr
Battery Capacity (Gel)	95Ah @20 hr
Sound Level	69 dBA
Cleaning path width	20 in (51 cm)
Squeegee width	34 in (86 cm)
Productivity (Traction Drive)	27,200 ft ² /hr (2,527 m ²)
Working speed (Traction Drive)	3.1 mph (5 km per hr)
Rated voltage	24 volts
Vacuum flow	65 cfm (110 m3/hr)
Vacuum waterlift	45 inches (112mbar)
Vacuum power	.60 HP (450 W)
Brush type	Disc
Brush motor(s) power	3/4 HP (560W)
Number of brushes	1
Brush RPM	180 RPM
Aqua-Stop equipped	Coming Soon
Solution capacity	12 Gal (45 liters)
Recovery capacity	13 Gal (49 liters)
Working Grade	2%
Weight with batteries	372 lbs (169 kg)
Weight without batteries	238 lbs (108 kg)
Dimensions (LxWxH)	47.4 x 21.3 x 42.3 (120.4 x 54.1 107.4 cm)
Drive Motor Power	1/5 HP (150W)

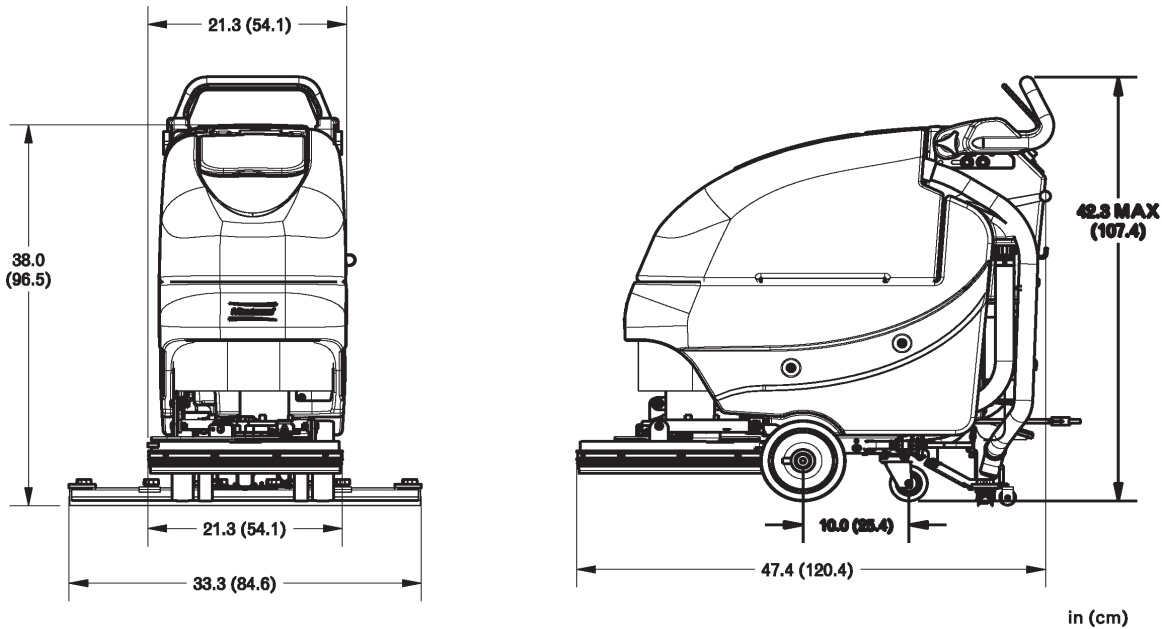

For Safety When Servicing or Maintaining Machine

- Stop on level surface.
- Disconnect the power to the machine by pulling the red Battery Connector located under the recovery tank near the batteries.
- Avoid moving parts. Do not wear loose jackets, shirts, or sleeves when working on machine.
- Avoid contact with battery acid. Battery acid can cause burns. When working on or around batteries, wear protective clothing and safety glasses. Remove metal jewelry. Do not lay tools or metal objects on top of batteries.
- Do not clean machine with a pressure washer.
- Authorized personnel must perform repairs and maintenance. Use PowerBoss supplied replacement parts.

Table of Contents

Main Assembly	1
Main Assembly BOM	2
Traction Drive Base Assembly	3
Traction Drive Base Assembly BOM	4
Base Assembly	5
Chassis Assembly	6
Chassis Assembly BOM	7
Solenoid Assembly	8
Solution Valve Assembly	8
Solution Tank Assembly	9
Lift Pedal Stop Assembly	10
Recovery Tank Assembly	11
Recovery Tank Assembly BOM	12
Handle Assembly	13
Battery Tray Assembly	14
Electrical Box Assembly	15
Electrical Box Assembly BOM	16
Electrical Box Cover Assembly	17
Vac Motor Assembly	18
20" Brush Deck Assembly	19
20" Brush Deck Assembly BOM	20
Brush Hub Assembly	21
Rear Squeegee Assembly	22
Squeegee Mechanism Assembly	23
WARRANTY	24

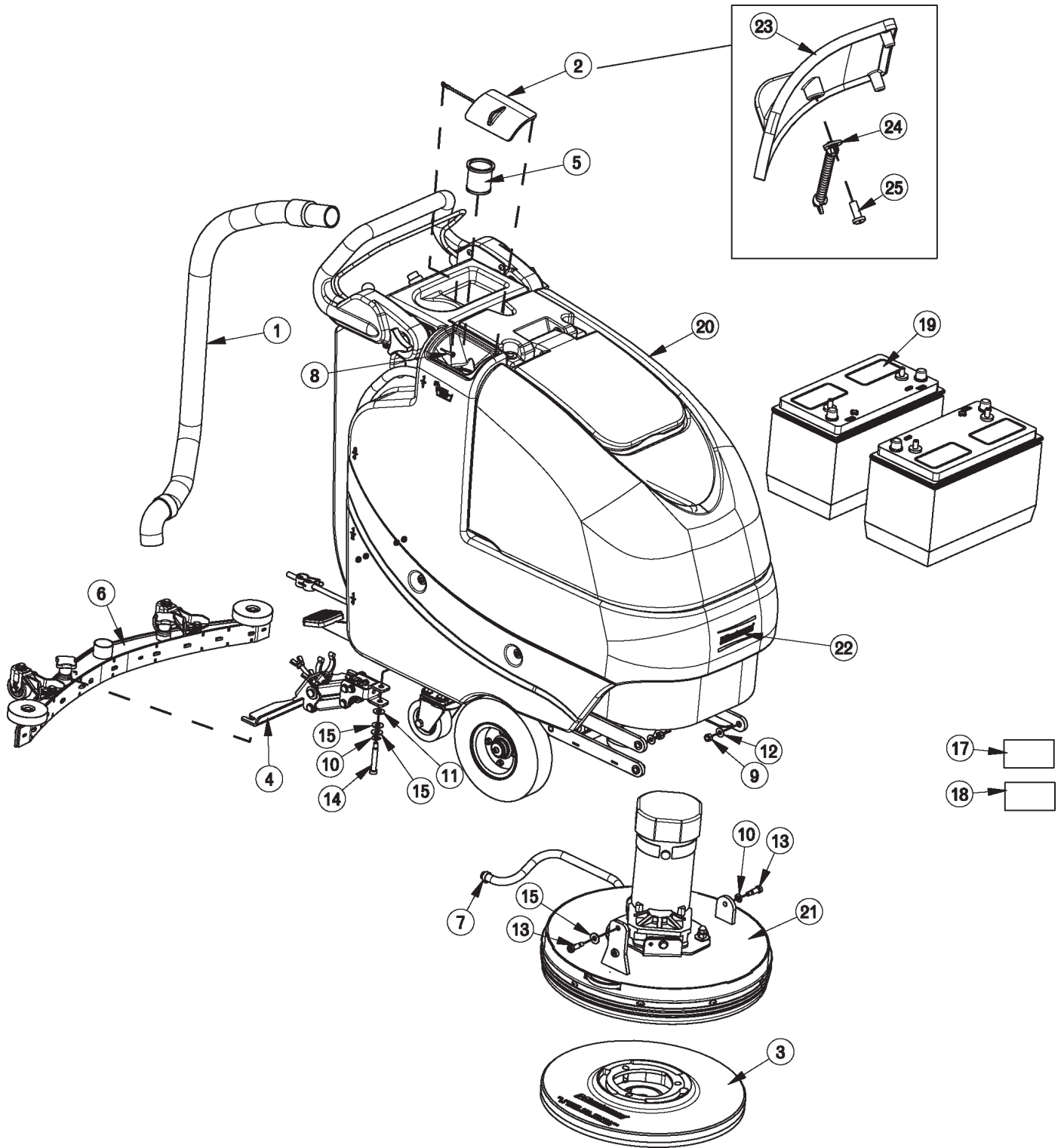

BILL OF MATERIAL			
ITEM	PART NO.	REQ'D	DESCRIPTION
1	172010	1	HOSE, CLEAR VAC W/ 45 CUFF
2	172018	1	SOLUTION TANK LID ASSY
3	172520-3	1	20" BRUSH, NYLOGRIT 80GR
4	172150	1	SQUEEGEE LIFT MECH ASSY
5	172159	1	FILTER, FILL PORT
6	172230	1	SQUEEGEE ASSY, 34" (860) CURVED
7	450076	1	CRIMP CLAMP SS 185R
8	711118	1	SCR-ST-A 10 X .75 SS
9	711374	4	NUT-NYLOC 5/16-18
10	711523	3	WSR-WAVE .37X .68 X .08
11	711569	1	WSR-FLT .390 X .880 X .062 NYL
12	711575	3	WSR-FLT .31x.75x.06ST
13	712081	3	SHOULDER BLT 5/16-18 X 3/8 X0.75
14	712143	1	BLT-SHLD 3/8 X 2.0, 5/16-18
15	712301	3	WSR-FLAT .37 X .87 X .06
16	715688	2	DECAL, PHOENIX (NOT SHOWN)
17	740164-1	1	JUMPER CABLE ASSY, RED 4G 12"
18	747649	1	CABLE ASSY, BATTERY
19	956140	2	BATTERY, 12V 140AH
19G	956100	2	GEL BATTERY 12V 95AH
20	172001TD-120	1	TRAC DRV BASE ASSY-120V CHARGER
21	172100TD	1	TD BRUSH DECK ASSY 20"
22	3334902	1	DECAL, POWERBOSS
23	172008	1	SOLUTION TANK LID
24	172123	1	CHAIN, BEADED SS W/ EYELETS

OPTIONAL BRUSHES		
ITEM	PART NO.	DESCRIPTION
3.1	172520-1	BRUSH, 20" NYLON
3.2	172520-2	BRUSH, 20" PAD DRIVER
3.3	172520-4	BRUSH, 20" STRATA GRIT 46GR
3.4	172520-5	BRUSH, 20" DYNASCRUB 500GR

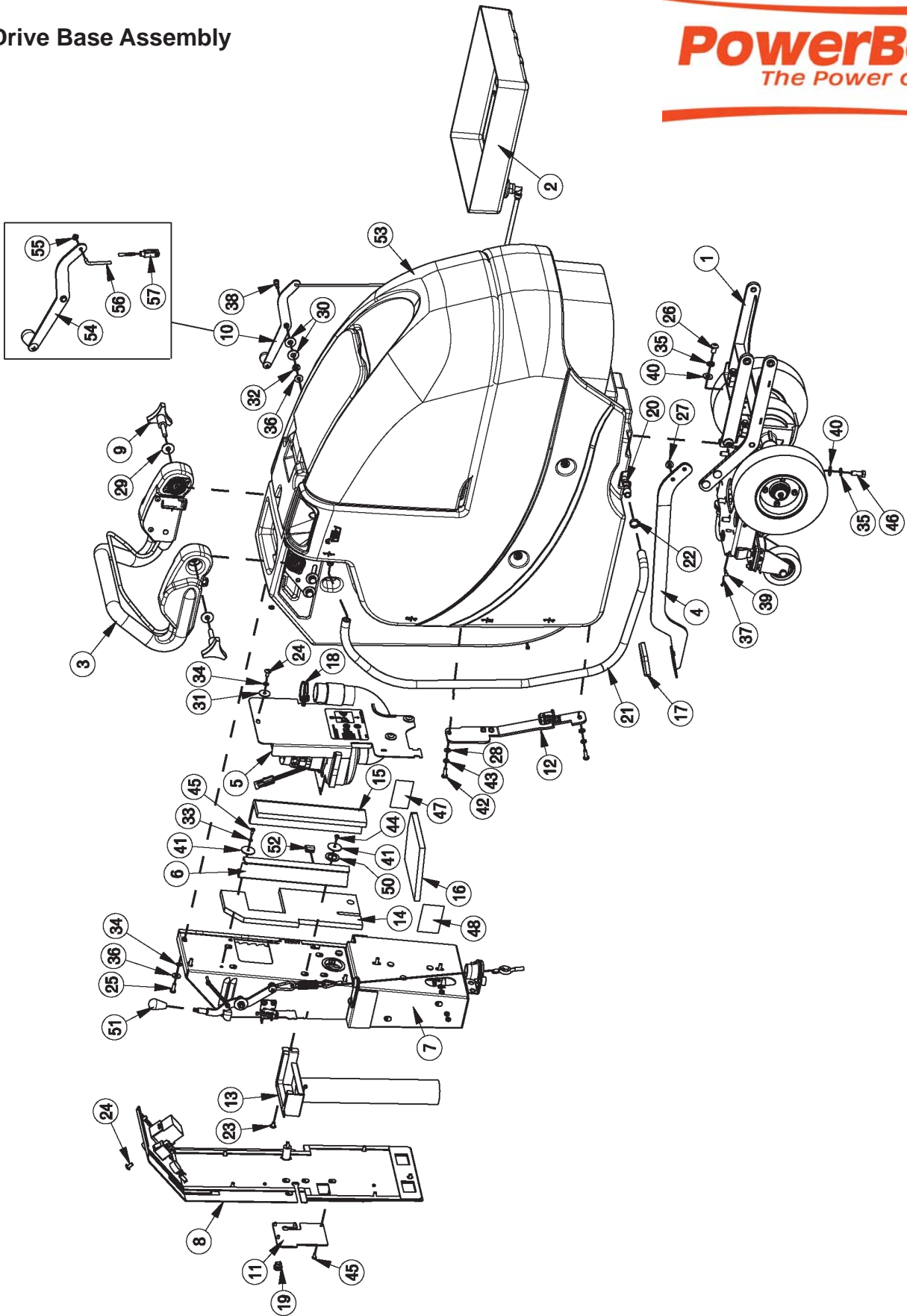



BILL OF MATERIAL - 172001TD-120

ITEM	PART NO.	REQ'D	DESCRIPTION	ITEM	PART NO.	REQ'D	DESCRIPTION
1	172009	1	TD CHASSIS ASSY	30	711508	2	WSR-FLAT .44X 1.0X.08
2	172012	1	BATTERY TRAY ASSY	31	711519	3	WSR- FLAT .25 X 1.01 X .06
3	172015	1	TD HANDLE ASSY	32	711523	1	WSR-WAVE .37X .68 X .08
4	172032	1	LIFT PEDAL WMT	33	711543	1	WSR-HELICAL #10
5	172050	1	VAC MOTOR ASSY	34	711544	9	WSR-HELICAL 1/4
6	172055	1	BKT, VAC AREA INSIDE COVER	35	711546	6	WSR-HELICAL 3/8
7	172075-120	1	ELEC BOX TD ASSY 120V	36	711575	6	WSR-FLT .31x.75x.06ST
8	172079	1	TD ELEC BOX COVER ASSY	37	711803	1	COTTER PIN-HAIR
9	172085	2	KNOB, 3/8-16 STUD, 3 LOBE	38	712041	1	BLT- SHLDR 1/4-20 X .44 X .37
10	172112	1	SOL CONTROL ASSY	39	712117	1	CLEVIS PIN
11	172129	1	BKT, PWR CORD MOUNT	40	712301	6	WSR-FLAT .37 X .87 X .06
12	172166	1	TD LIFT PEDAL BKT ASSY	41	712312	2	WSR-FLAT .187 X 1.25
13	172179	1	CHARGER INLET ASSEMBLY	42	712562	2	BOLT-HH 1/4-20X3/4 SS
14	172184	1	FOAM COVER, REAR 1	43	712758	2	WSR-HELICAL 1/4 SS
15	172185	1	FOAM COVER, REAR 2	44	712800	1	SCR-MC 10-24 X .25 ST PL
16	172187	1	FOAM COVER, FRONT 2	45	712810	5	SCR-MC 10-24 X .37 ST PL
17	210142	1	PEDAL PAD	46	713042	4	BLT-HH 3/8-16 X 1 #5
18	260203	1	WIRE GRIP HOSE CLAMP	47	715029	1	DECAL-NAME PLATE SERIAL
19	293080	1	STRAIN RELIEF-HEYCO 1207	48	715047	1	DECAL-CLEAR LAMINATE 2X3
20	342440	1	FITTING, TEE 3/4MPT 1/2BARB PP	49	715950	1	LABEL, PATENT NUMBERS
21	430156	1	HOSE, 1/2 X 42 CLEAR	50	717025	1	WSR-FLAT 13/16ID X 1.25 X .08
22	450093	2	CRIMP CLAMP 3/4" STEPLESS	51	760592	1	KNOB, OVAL TAPERED
23	710177	1	SCR-MC 1/4-20 X .37 ST PL	52	809443	1	CLIP-WIRE & CORD
24	710178	10	SCR-MC 1/4-20 X .50 TRUSS STPL	53	172001BASE	1	BASE ASSY
25	710380	5	SCR-MC RD HD 1/4-20 X .75 STL PL	54	172115	1	SOL CNTRL LEVER ASSY
26	710985	2	SCR-SC 3/8-16 X .62 ST PL	55	172122	1	NUT, PUSH-ON WSR CAP, 3/16
27	711379	2	NUT, FLANGED WIZZ 5/16-18	56	172069	1	ROD, SOL. CTRL
28	711504	2	WSR-FLAT 1/4 ID SS	57	172062	1	YOKE, 3/16 CLEVIS, 10-32, LONG
29	711507	2	WSR-FLAT .37 X 1.12 X .06				

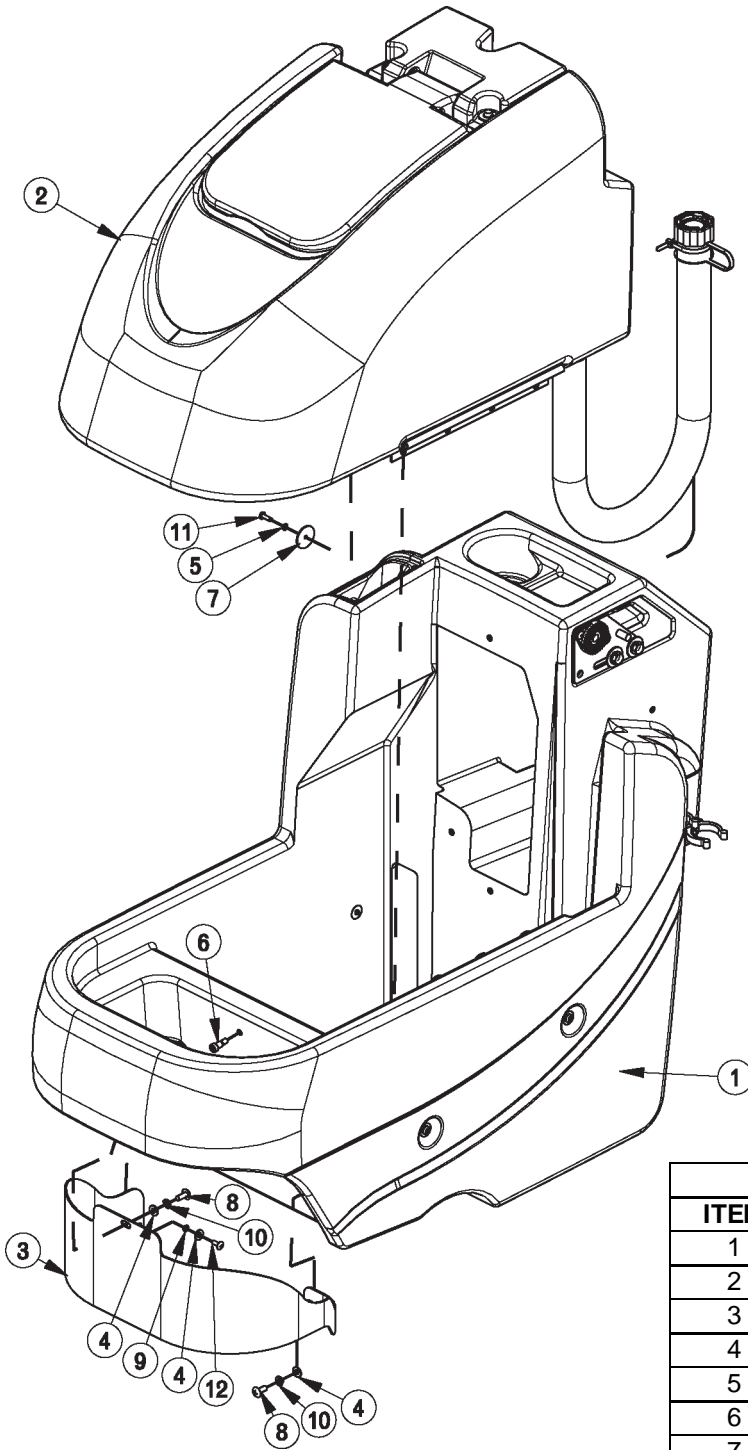

BILL OF MATERIAL - 172001BASE

ITEM	PART NO.	REQ'D	DESCRIPTION
1	172013	1	SOL TANK ASSY
2	172014	1	REC TANK ASSY
3	172144	1	PANEL, FRONT
4	711504	3	WSR-FLAT 1/4 ID SS
5	711543	4	WSR-HELICAL #10
6	712041	1	BLT- SHLDR 1/4-20 X .44 X .37
7	712312	4	WSR-FLAT .187 X 1.25
8	712565	2	SCR-MC 1/4-20X.63 SS TR HD
9	712757	1	WSR - HELICAL #10 SS
10	712758	2	WSR-HELICAL 1/4 SS
11	712812	4	SCR-MC 10-24 X .62 PPH ST PL
12	712822	1	SCR-MC TR HD 10-24 X .50 SS

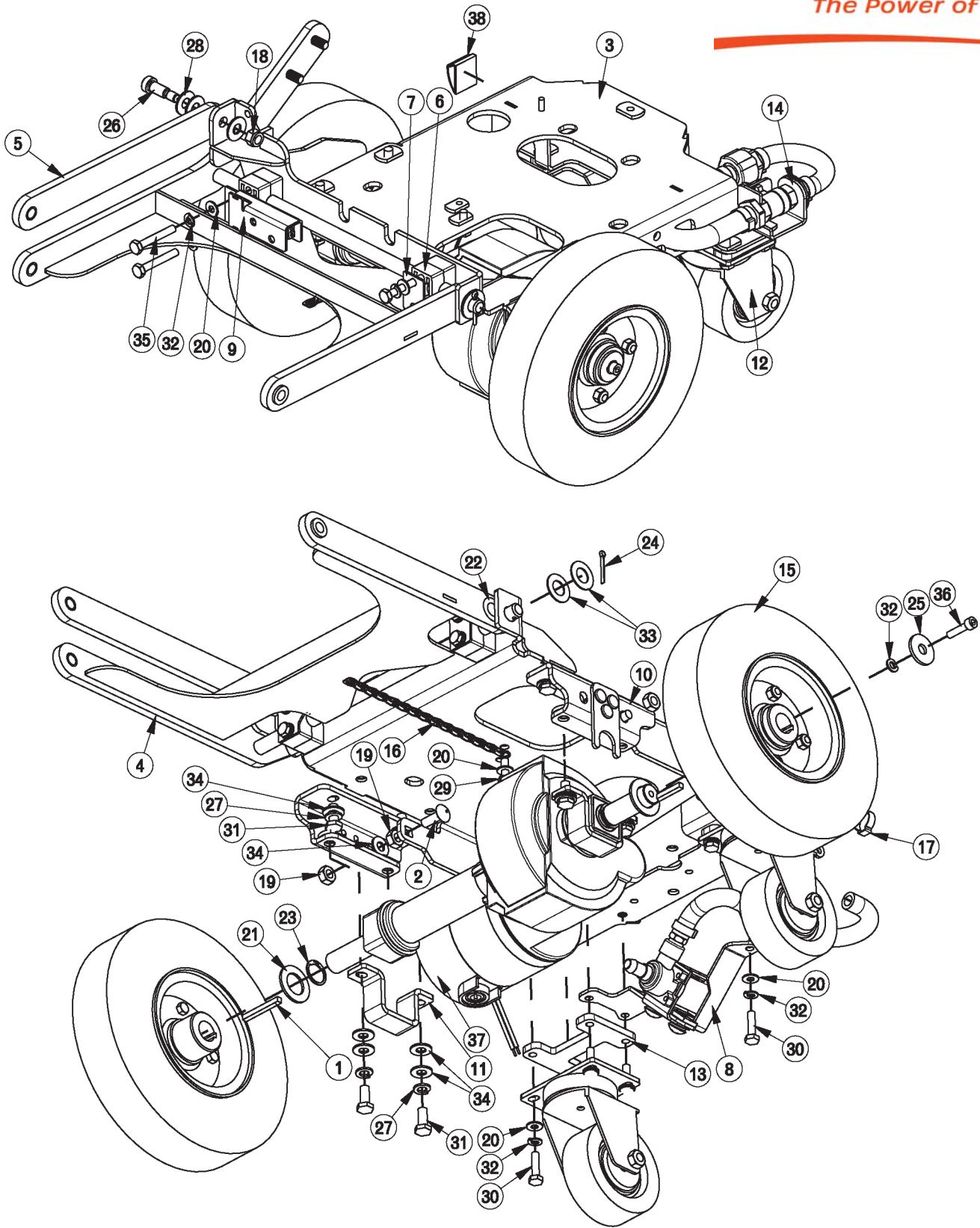

BILL OF MATERIAL - 172009			
ITEM	PART NO.	REQ'D	DESCRIPTION
1	61-65-A	2	KEY, 3/16 X 1-3/4"
2	70-516-16	2	BLT-CAR 5/16-18 X 1.00
3	172020	1	MAIN FRAME WMNT
4	172025	1	DECK LIFT ASSY
5	172030	1	BAR, UPPER DECK LIFT W/ BUSH
6	172038	4	BEARING BLOCK
7	172039	1	BEARING BLOCK PLATE
8	172104	1	TD SOLENOID ASSY
9	172110	1	DECK SWITCH ASSY
10	172113	2	BKT, TRANSAXLE MOUNT BASE
11	172114	2	BKT, TRANSAXLE MOUNT
12	172167	2	CASTER, 3-1/2 POLYURETHANE
13	172192	2	PLATE, 1/4" SPACER
14	172264	1	SOLUTION VALVE ASSY
15	200172-2	2	WHEEL, 8.5" FOAM FILL
16	281200	1	DRAG CHAIN ASSY, FRAME
17	450076	1	CRIMP CLAMP SS 185R
18	711374	1	NUT-NYLOC 5/16-18
19	711383	4	NUT-HEX CLR LOC 5/16-18
20	711504	13	WSR-FLAT 1/4 ID SS
21	711512	2	WSR-FLAT .75X1.37X.08
22	711592	2	WSR-FLAT .50 X .9 X .075 NYL
23	711715	2	RETAINING RING EXT .75
24	711809	1	COTTER PIN, 1/8 X 1.0
25	711855	2	WSR-FLT .37X1.12X.10 STL Z HARD
26	712081	1	SHOULDER BLT 5/16-18 X 3/8 X .75
27	712140	8	WSR-HELICAL 5/16 SS
28	712301	3	WSR-FLAT .37 X .87 X .06
29	712562	1	BOLT-HH 1/4-20X3/4 SS
30	712564	8	BOLT-HH 1/4-20X1.00 SS
31	712575	8	BLT-HH 5/16-18 X .75 SS
32	712758	14	WSR-HELICAL 1/4 SS
33	712760	2	WSR-FLAT .56X1.06X.04 SS
34	712772	14	WSR-FLAT .344 x .75 x .06 SS
35	713006	4	BLT-HH 1/4-20 X 1 3/4 #5
36	717026	2	SCR-SC SHCS M6X1.0 X 25 STL Z
37	747606	1	TRANSAXLE, ES1720 24V
38	809444	1	CLIP-CORD

Solenoid Assembly

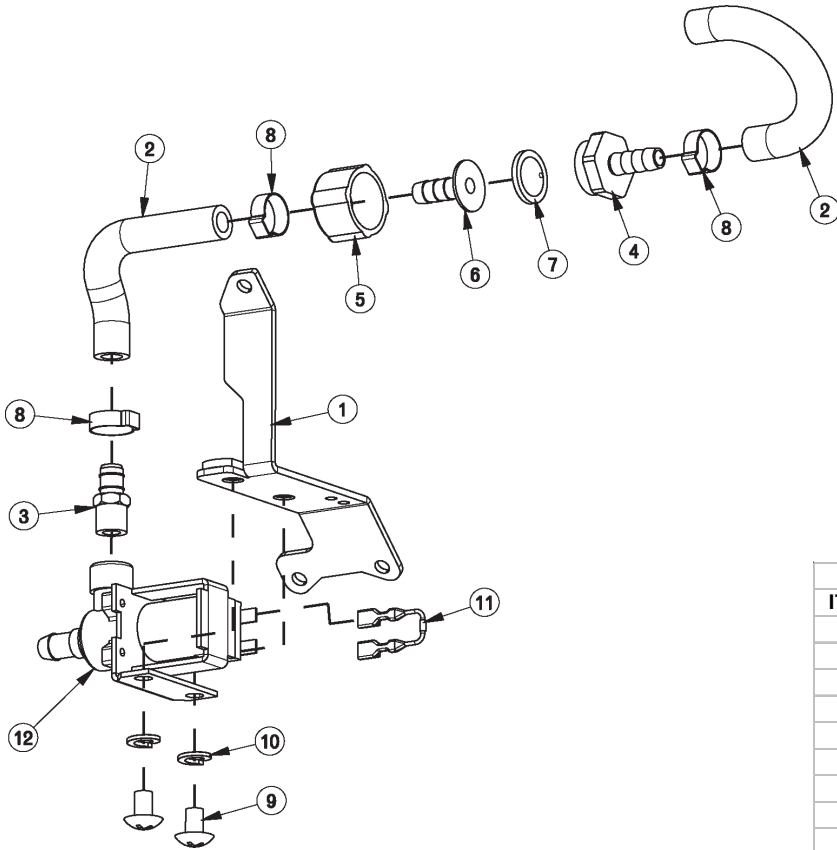

BILL OF MATERIAL - 172104			
ITEM	PART NO.	REQ'D	DESCRIPTION
1	172105	1	BKT, SOLENOID MOUNT
2	172164	2	HOSE-WIRE REINF 3/8 X 5.5"
3	320264	1	FITTING-DBL 1/4MPT 3/8HO BRASS
4	342441	1	FITTING, MIGHT X 3/8HB PP
5	342442	1	FITTING, FGHT NUT - PP
6	342443	1	FITTING, 3/8HB INSERT - PP
7	342444	1	WSR-FILTER, GARDEN HOSE SIZE
8	450076	3	CLAMP-CRIMP 185R SS
9	710195	2	SCR-MC 5/16-18 X .50 ZINC
10	711545	2	WSR-HELICAL 5/16
11	740482	1	DIODE ASY, 1N4007 W/PIGGY
12	740493	1	VALVE-WATER 24VDC

Solution Valve Assembly

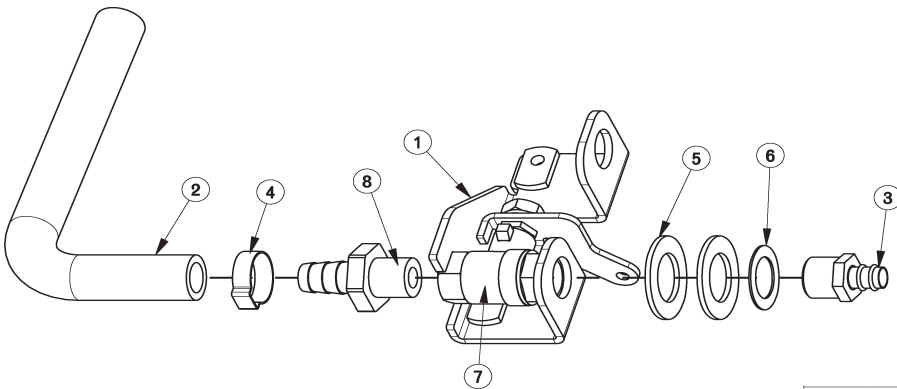

BILL OF MATERIAL - 172064			
ITEM	PART NO.	REQ'D	DESCRIPTION
1	172063	1	BKT, SOL VALVE MOUNT
2	172158	1	HOSE, 1/2"ID X 7.5" NYLOBRAID
3	320265	1	FITTING DUBL 3/8HBx3/8MPT
4	383347	1	CRIMP CLAMP 1/2 HOSE SS 185R
5	711512	2	WSR-FLAT .75X1.37X.08
6	711513	1	WSR-FLAT .69 X 1.06 X .03 SS
7	809415	1	VALVE, 3/8 FPT, 45 OPEN/CLOSE
8	827008	1	FITTING, 3/8 MPT 1/2 HOSE

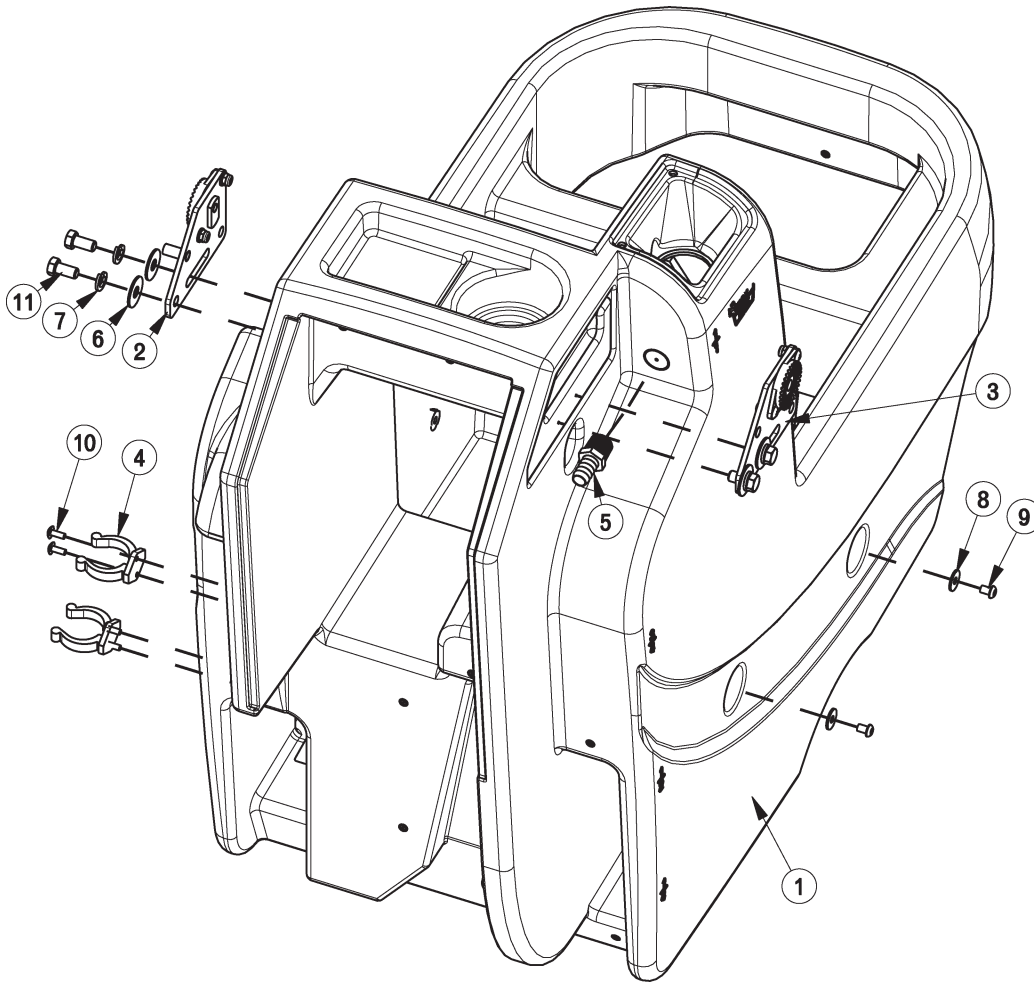

BILL OF MATERIAL - 172013			
ITEM	PART NO.	REQ'D	DESCRIPTION
1	172003	1	SOLUTION TANK
2	172080	1	HANDLE MOUNT ASSY, LEFT
3	172082	1	HANDLE MOUNT ASSY, RIGHT
4	260579	2	TOOL CLIP, 1.5" HOSE
5	342438	1	FITTING, 1/2 MPT 1/2 HB BRASS
6	711507	4	WSR-FLAT .37 X 1.12 X .06
7	711546	4	WSR-HELICAL 3/8
8	711550	4	WSR NYLON .25 ID X .75 OD
9	712146	4	SCR-SC BHCS 1/4-20 X .37 SS
10	712822	4	SCR-MC TR HD 10-24 X .50 SS
11	713041	4	BLT-HH 3/8-16 X 3/4 #5

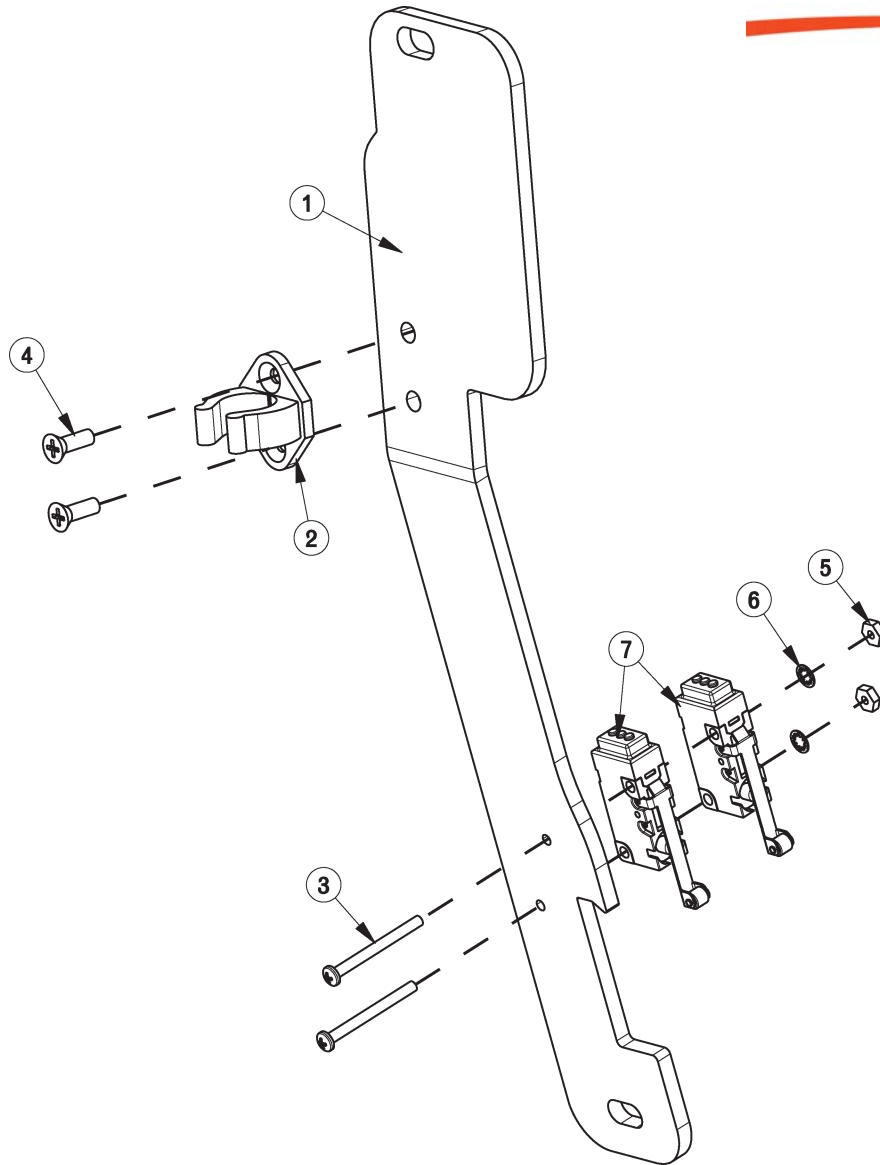

BILL OF MATERIAL - 172166			
ITEM	PART NO.	REQ'D	DESCRIPTION
1	172036	1	BKT, PEDAL STOP
2	172065	1	CLIP, FOR 1/2" ID HOSE
3	710495	2	SCR-MC 4-40 X 1.25 STL Z
4	710530	2	SCR-MC FL HD 8-32 X .50 BRS
5	711428	2	NUT-HEX 4-40
6	712326	2	WSR-INT LOCK #4
7	747603-2	2	SWITCH ASY, MICRO ROLLER W/PACK/CONDUIT

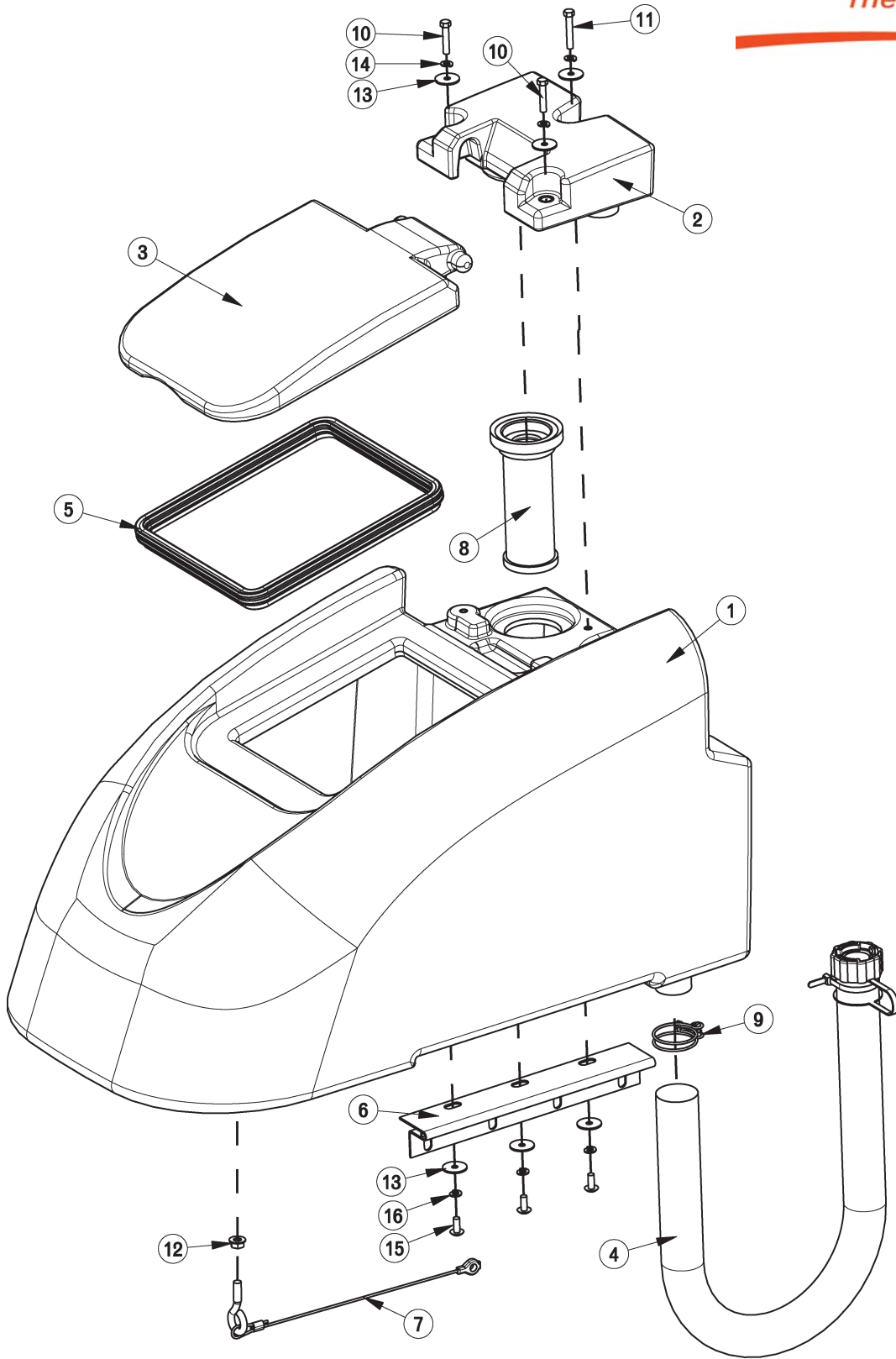



BILL OF MATERIAL - 172014			
ITEM	PART NO.	REQ'D	DESCRIPTION
1	172004HR	1	RECOVERY TANK ORANGE
2	172005HR	1	VACUUM MANIFOLD
3	172007	1	LID
4	172011	1	HOSE, PINCH-OFF W/ CAP, 36"
5	172017	1	GASKET, LID
6	172049	1	HINGE, RECOVERY TANK
7	172067	1	REC TANK CABLE ASSY 11.625
8	172132	1	SCREENED FLOAT
9	172329	1	WIRE GRIP HOSE CLAMP
10	711210	2	BLT-HH 1/4-20 X 1.25 STPL
11	711212	1	BLT-HH 1/4-20 X 1.50 STPL
12	711379	1	NUT, FLANGED WIZZ 5/16-18
13	711519	6	WSR- FLAT .25 X 1.01 X .06
14	711544	3	WSR-HELICAL 1/4
15	712565	3	SCR-MC 1/4-20X.63 SS TR HD
16	712758	3	WSR-HELICAL 1/4 SS

Handle Assembly

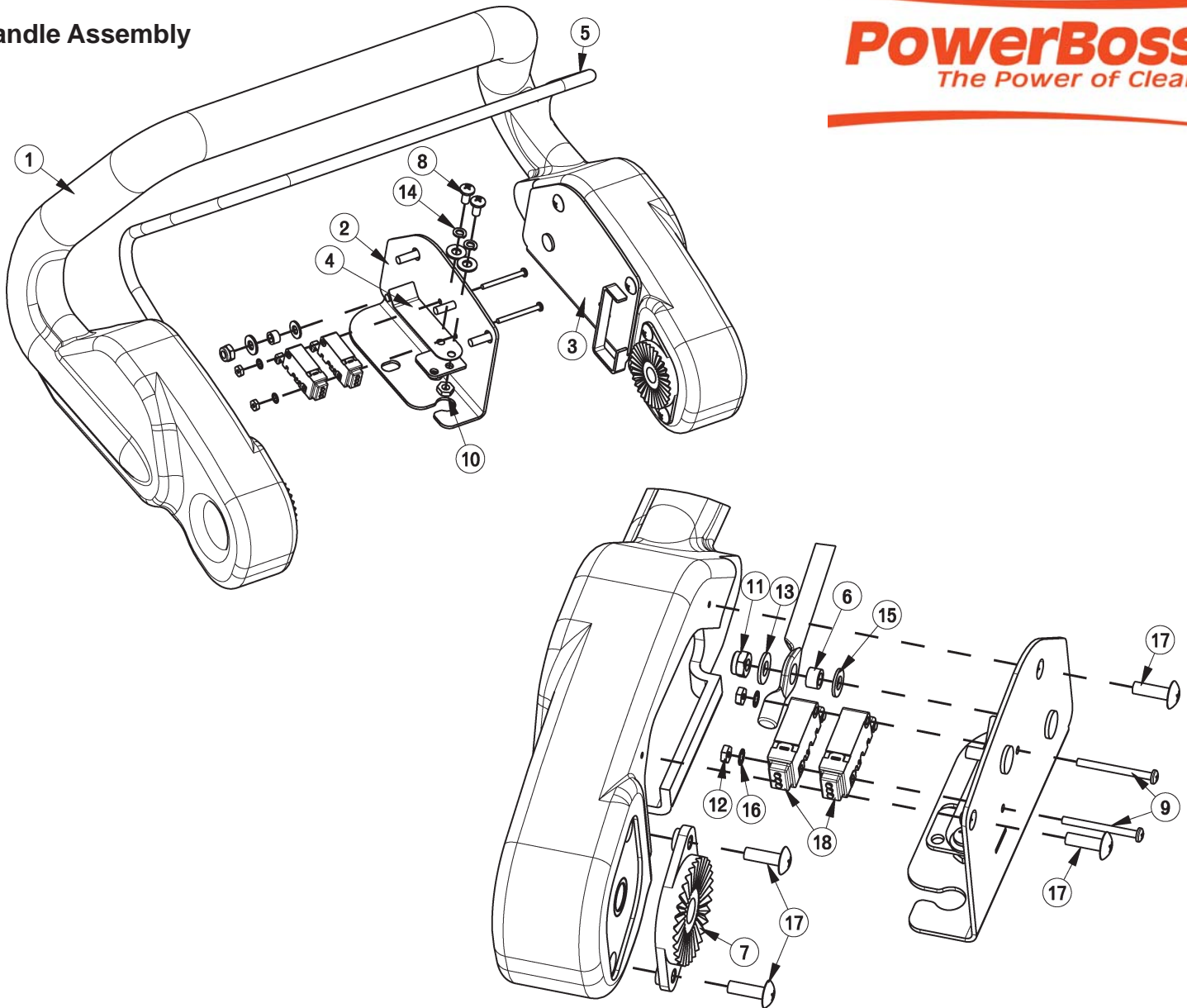

BILL OF MATERIAL - 172015

ITEM	PART NO.	REQ'D	DESCRIPTION	ITEM	PART NO.	REQ'D	DESCRIPTION
1	172006	1	HANDLE	11	711350	2	NUT-NYLOC 10-32
2	172053	1	BAIL PLATE WMT RH	12	711428	2	NUT-HEX 4-40
3	172054	1	BAIL PLATE WMT LH	13	711503	6	WSR, FLAT#10
4	172057	2	LEAF SPRING	14	711543	4	WSR-HELICAL #10
5	172059	1	BAIL, HANDLE	15	712320	2	WSR-NYLON .22 X .45 X .04
6	172074	2	SPACER, 5/16OD X 17GA, ALUM	16	712326	2	WSR-INT LOCK #4
7	270143	2	HANDLE PIVOT JAW	17	712830	10	SCR-MC 10-24 X .62 STLZ TR HD
8	710353	4	SCR-MC RD HD 10-32 X .37 STL	18	747603-1	2	SWITCH ASY, MICRO ROLLER W/PACK/CONDUIT
9	710495	2	SCR-MC 4-40 X 1.25 STL Z	19	747632-1	1	CABLE ASY, 5 COND 18G CONSOLE
10	711310	4	NUT, HEX 10-32 ST PL				

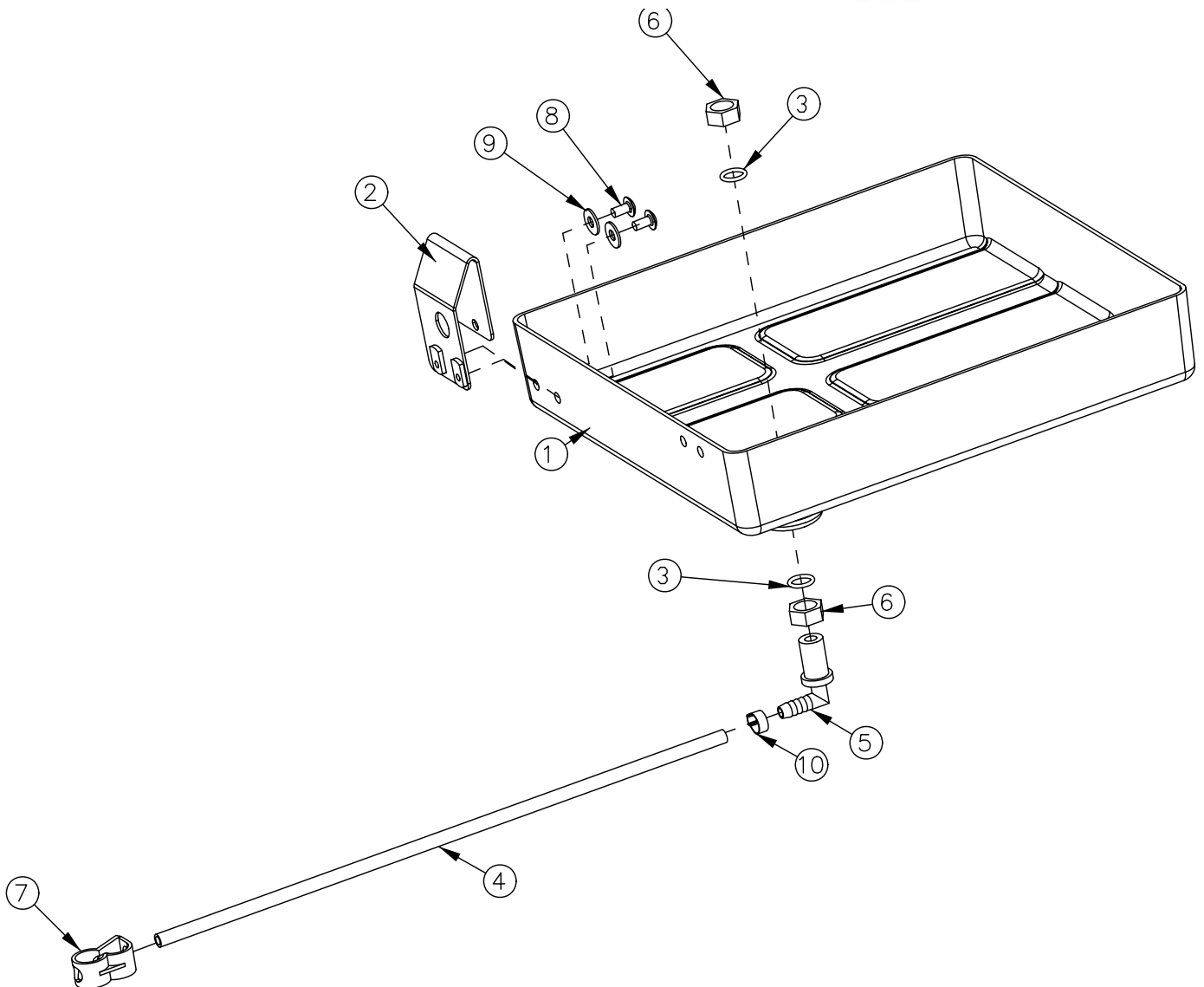

BILL OF MATERIAL - 172012

ITEM	PART NO.	REQ'D	DESCRIPTION
1	172116	1	BATTERY BOX
2	172213	1	BKT, SPACER FOR BATTERIES
3	210414	2	O RING 2-113
4	260224	1	18" HOSE
5	320271	1	NOZZLE BODY-ELBOW
6	320272	2	NOZZLE BODY LOCKNUT
7	320273	1	HOSE SHUT-OFF CLAMP
8	710178	2	SCR-MC 1/4-20 X .50 TRUSS STPL
9	711575	2	WSR-FLT .31x.75x.06ST
10	828490	1	CRIMP CLAMP 140R

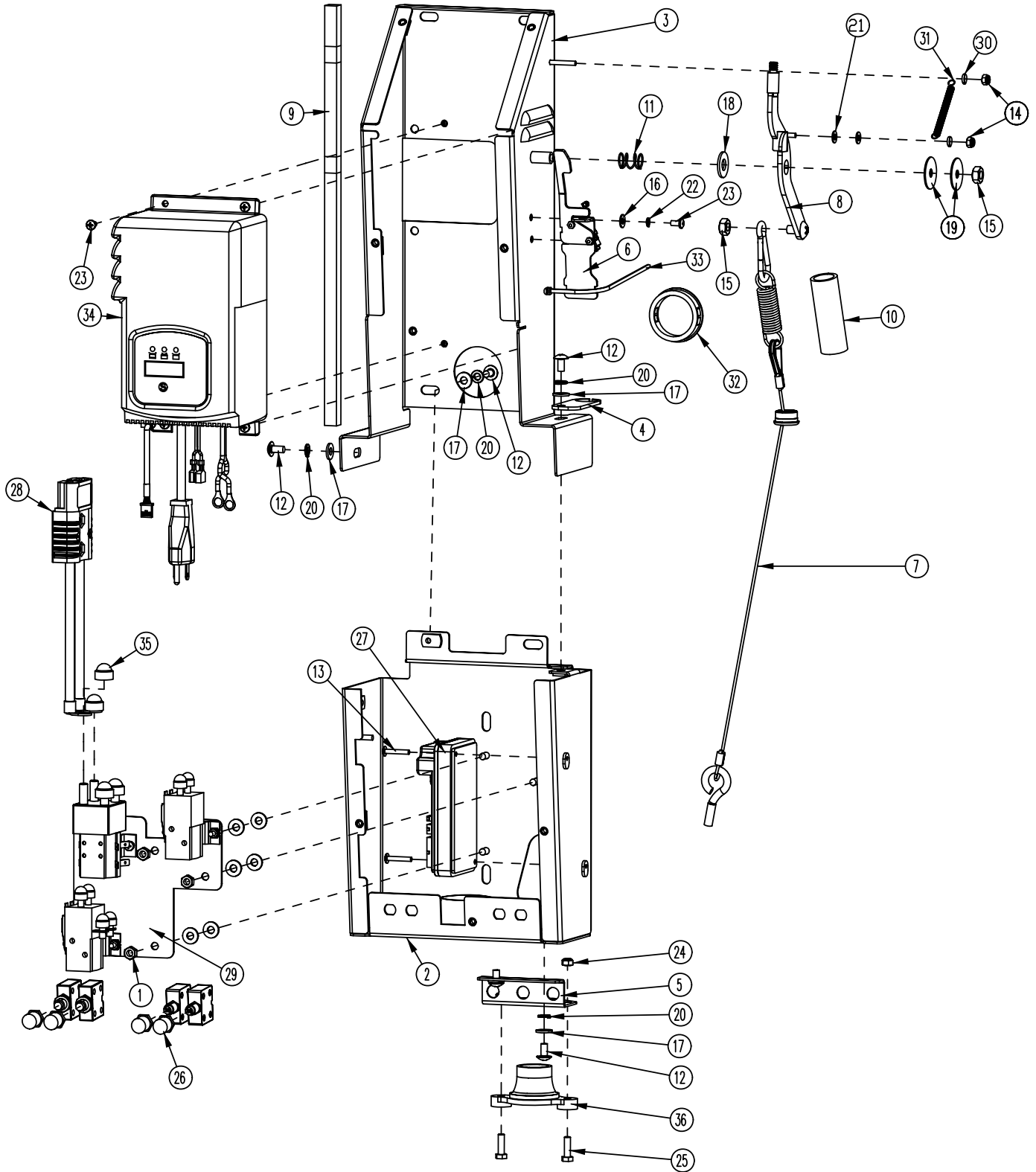

BILL OF MATERIAL - 172075-120			
ITEM	PART NO.	REQ'D	DESCRIPTION
1	369-416	3	NUT-HEX 1/4-20 NYLOC SERRATED
2	172077	1	ELEC BOX-BOT HALF WMT
3	172088	1	ELEC BOX-TOP HALF WMT
4	172107	1	BKT, UPPER BUSHING MOUNT
5	172128	1	BKT, LOWER BUSHING MOUNT
6	172141	1	VAC SWITCH ASSY
7	172149	1	CABLE ASSY, SQUEEGEE LIFT
8	172152	1	VAC LEVER WMT
9	172188	1	FOAM TAPE, 1/2" SQ X 16.5"
10	172331	1	PIPE, 3/4 X 3.0 SCHD 40 PVC
11	670093	1	SPRING, COMPRESSION
12	710178	5	SCR-MC 1/4-20 X .50 TRUSS STPL
13	710534	2	SCR-MC TR HD 8-32 X 1.00 SS
14	711372	2	NUT-NYLOC 8-32 STL ZINC
15	711383	2	NUT-HEX CLR LOC 5/16-18
16	711503	2	WSR, FLAT#10
17	711505	11	1/4 FLAT WASHER, STEEL
18	711508	1	WSR-FLAT .44X 1.0X.08
19	711516	2	WSR- FLAT .31 X 1.25 X .05
20	711544	5	WSR-HELICAL 1/4
21	712320	2	WSR-NYLON .22 X .45 X .04
22	712757	2	WSR - HELICAL #10 SS
23	712810	6	SCR-MC 10-24 X .37 ST PL
24	717018	2	NUT-NYLOC M6 X 1.0
25	717022	2	BOLT-HH M6X1.0 X 20
26	742748	4	CIRCUIT BREAKER BOOT
27	747608	1	I-DRIVE,24V 70A PM MOTOR CONTROL
28	747637	1	WIRE ASY, MACHINE-BATTERY
29	747670	1	ELEC PANEL ASSY
30	760134	2	MOUNT RING
31	762084	1	SPRING-EXT .25OD X 2" F.L. MUSIC
32	762400	1	HEYCO BUSHING 2.00"
33	828062	1	CABLE TIE LARGE
34	957745	1	CHARGER,24VDC 12A ON-BOARD 120VAC
35	15592033	2	CAP, SAFETY NUT COVER M8
36	90508391	1	BUSHING, CABLE GUIDE, HAKO

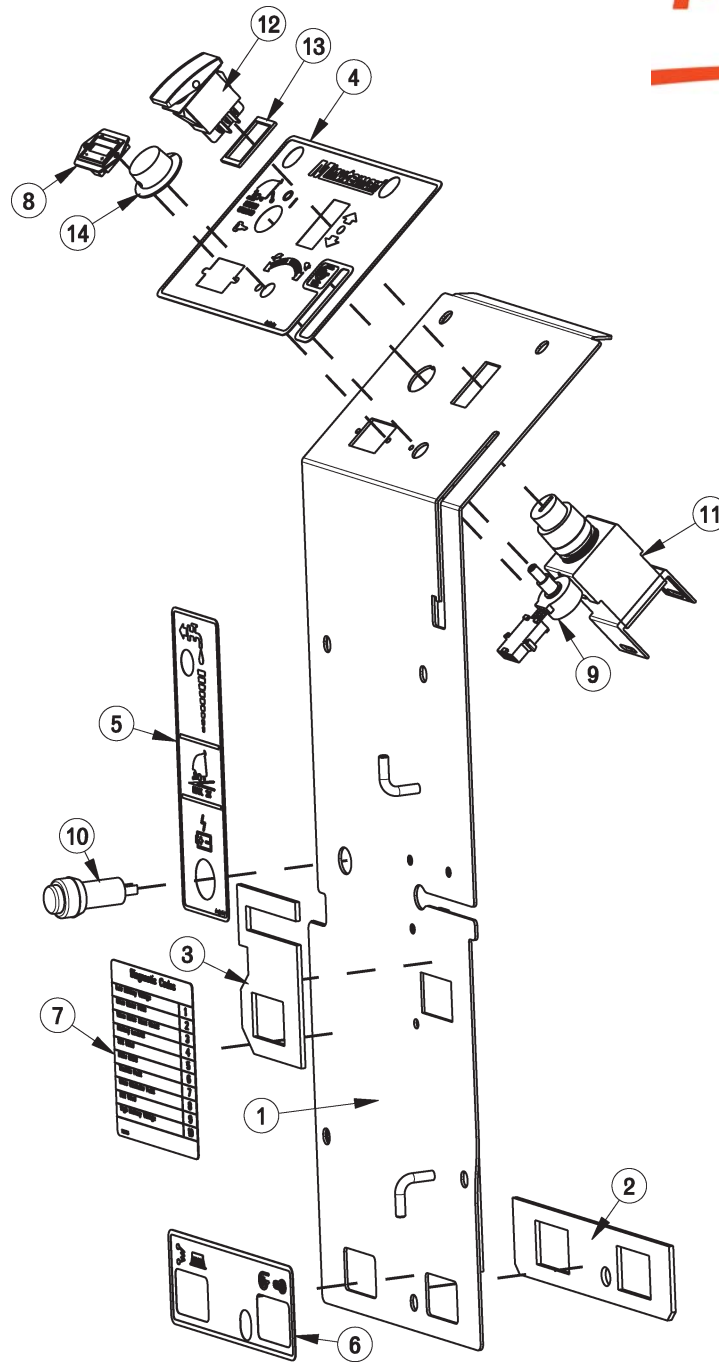

BILL OF MATERIAL - 172079PB

ITEM	PART NO.	REQ'D	DESCRIPTION	ITEM	PART NO.	REQ'D	DESCRIPTION
1	172182	1	TD COVER WMT	8	747011	1	BATTERY GAUGE, TRUCHARGE
2	172193	1	GASKET, CB OUTLINE	9	747026	1	POTENTIOMETER ASSY SPEED CONTROL
3	172194	1	GASKET, CHARGER CORD PLATE	10	747614	1	CHARGE STATUS INDICATOR
4	715682	1	DECAL, TD DASHBOARD	11	747617-2	1	KEYSWITCH ASY, KEYSWITCH + WIR
5	715672	1	DECAL, BD ELEC BOX	12	748201	1	SWITCH, DPDT ON/OFF/ON
6	715674	1	DECAL, TD CIRCUIT BREAKER	13	748209	1	GASKET-FOR 2 POLE ROCKER SWITCHES
7	715678	1	DECAL. DIAGNOSTIC CODES	14	809874	1	KNOB, SPEED CONTROL

Vac Motor Assembly

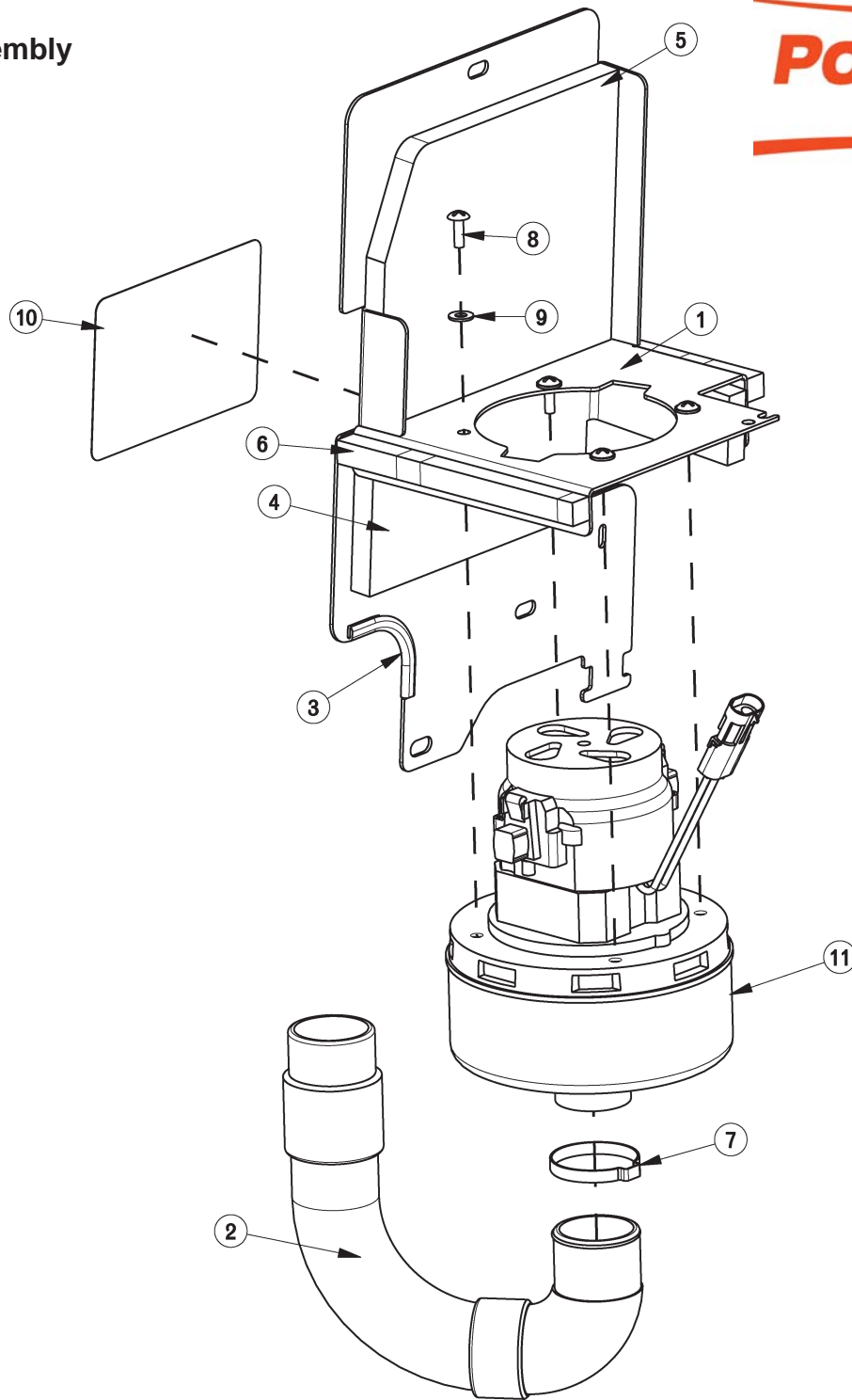

BILL OF MATERIAL - 172050

ITEM	PART NO.	REQ'D	DESCRIPTION	ITEM	PART NO.	REQ'D	DESCRIPTION
1	172045	1	VAC MOUNT WMT	7	450095	1	CRIMP CLAMP, 1.75"
2	172048	1	HOSE, STRETCH 13"	8	711160	4	#10 X 5/8 HI-LO
3	172124	1	EDGE TRIM, .063 X 3.0, BLACK	9	711503	4	WSR, FLAT#10
4	172186	1	FOAM COVER, FRONT 1	10	715676	1	DECAL, BATT CABLE ROUTE
5	172187	1	FOAM COVER, FRONT 2	11	747607-1	1	VAC MOTOR ASY
6	172188	2	FOAM TAPE, 1/2" SQ X 16.5"				

20" Brush Deck Assembly

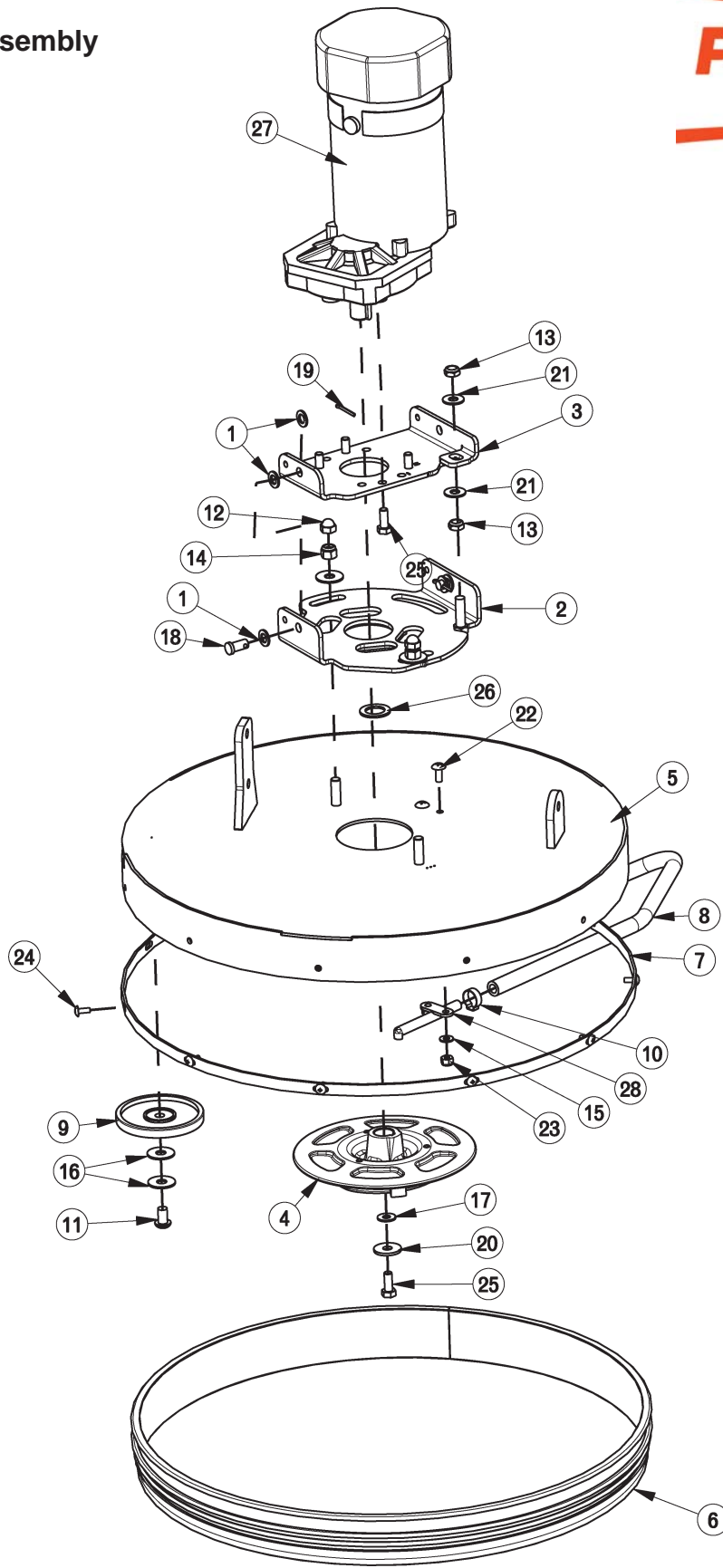

BILL OF MATERIAL - 172100TD			
ITEM	PART NO.	REQ'D	DESCRIPTION
1	81-166-A	6	SPECIAL WASHER
2	172040	1	DECK ANGLE ADJUST WMT
3	172044	1	PLATE, MOTOR MOUNT
4	172095	1	E20 BRUSH HUB ASSY
5	172101	1	DECK COVER WMT 20"
6	172121	1	20" DECK SKIRT
7	172125	1	RETAINER, 20" DECK SKIRT
8	172198	1	HOSE-NYLO REINF 3/8 X 25"
9	210153	1	ROLLER WHEEL
10	450076	1	CRIMP CLAMP SS 185R
11	710985	1	SCR-SC 3/8-16 X .62 ST PL
12	711354	2	NUT-ACORN 3/8-16 ST NI
13	711375	2	NUT-NYLOC 3/8-16 X 1/2 NUT
14	711380	2	NUT-NYLOC 3/8-16 NUT
15	711504	2	WSR-FLAT 1/4 ID SS
16	711507	4	WSR-FLAT .37 X 1.12 X .06
17	711545	1	WSR-HELICAL 5/16
18	711679	2	CLEVIS PIN 3/8 X 3/4
19	711809	2	COTTER PIN, 1/8 X 1.0
20	711855	1	WSR-FLT .37X1.12X10 STL Z HARD
21	712301	2	WSR-FLAT .37 X .87 X .06
22	712565	2	SCR-MC 1/4-20X.63 SS TR HD
23	712667	2	NUT, HEX 1/4-20 NYLOC SS
24	712822	11	SCR-MC TR HD 10-24 X .50 SS
25	717024	5	BOLT-HH M8X1.25 X 20
26	717025	1	WSR-FLAT 13/16ID X 1.25 X .08
27	747600	1	MOTOR, OFFSET PM GEAR, 550W
28	90311663	1	HAKO SOL FEED NOZZLE

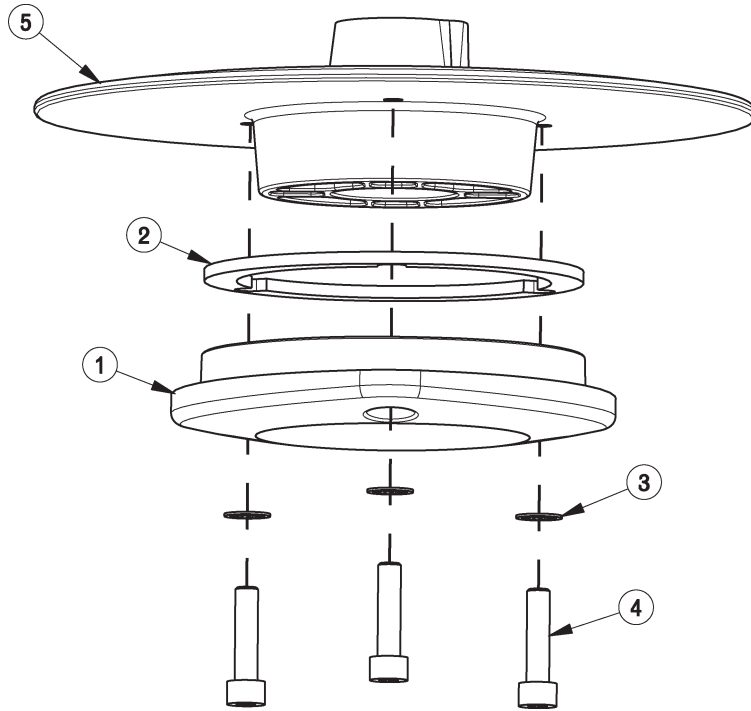

BILL OF MATERIAL - 172095			
ITEM	PART NO.	REQ'D	DESCRIPTION
1	172097	1	BRUSH HUB BASE
2	172133	1	BRUSH HUB SPACER
3	711554	3	WSR-INTERNAL LOCK 1/4 ID
4	717026	3	SCR-SC SHCS M6X1.0 X 25 STL Z
5	172096MCH	1	BASE, DRIVE HUB WITH KEYWAY

Rear Squeegee Assembly

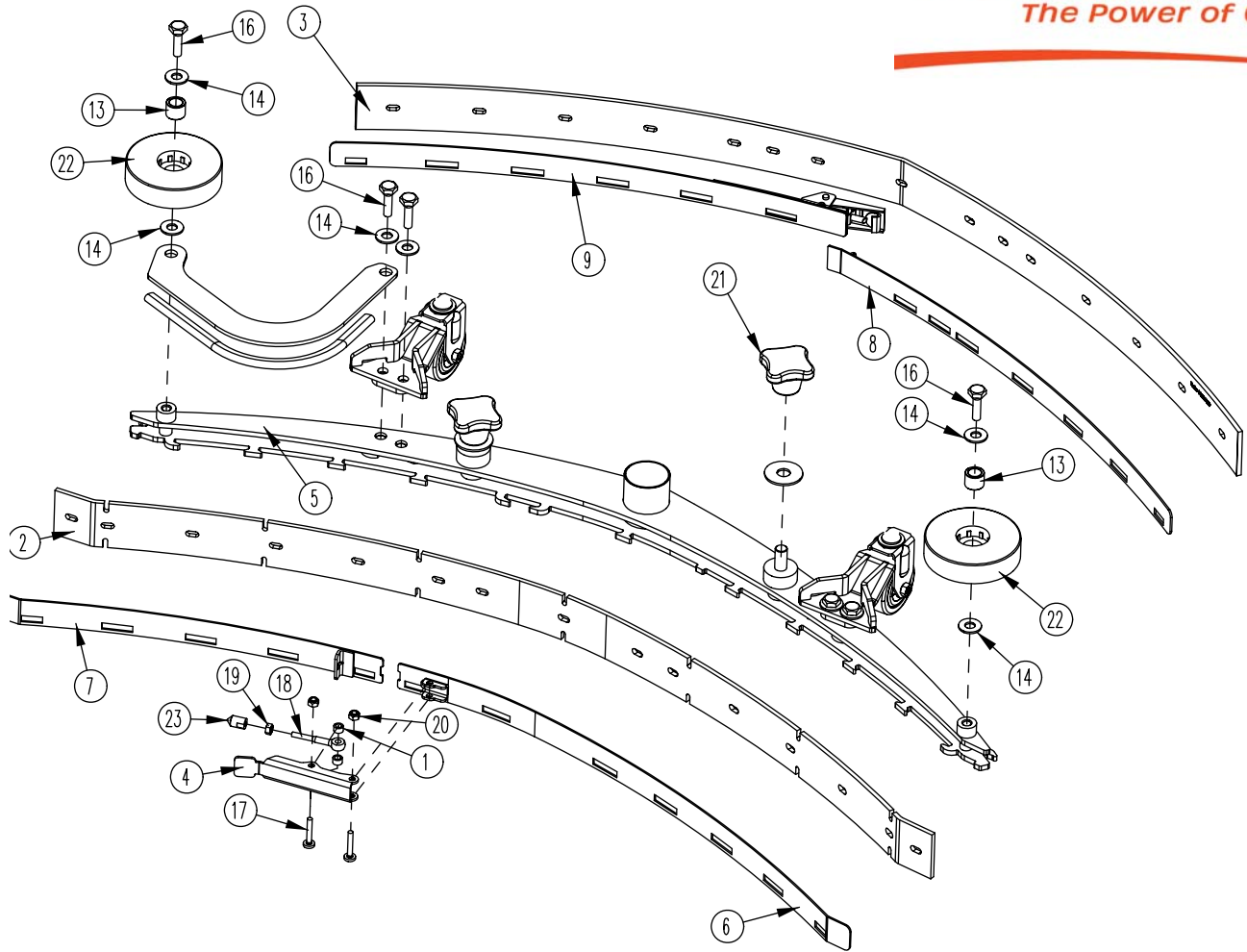

BILL OF MATERIAL - 172230

ITEM	PART NO.	REQ'D	DESCRIPTION
1	172074	2	SPACER, 5/16OD X 17GA, ALUM
2	172162	1	BLADE, FRONT 34" SQUEEGEE
3	172163	1	BLADE, REAR 34" SQUEEGEE
4	172234	1	LEVER, 90535758
5	172235	1	SQUEEGEE WMT, 34" (860)
6	172240	1	STRAP WMT, FRONT LEFT
7	172241	1	STRAP WMT, FRONT
8	172245	1	STRAP WMT, REAR
9	172246	1	STRAP WMT, REAR
10	172250	2	SQUEEGEE CASTER ASSY
11	172271	1	BUMPER, 34" SQG
12	172274	1	EDGE TRIM 5/16 X 10" BLACK
13	430322	2	BUSHING .435 X .625 X .50
14	712772	8	WSR-FLAT .344 x .75 x .06 SS
15	712773	2	WSR FLAT .438 X 1.25 X .07 SS
16	11039567	6	BLT-HH M8 X 25 SS DIN933
17	11175494	2	SCR-MC M5 X 25 SS DIN7985
18	11518313	1	BLT-EYE M5 X 40 SS
19	12022430	1	NUT-HEX M5 SS DIN934
20	12040283	2	NUT-HEX M5 NYLOC SS DIN985
21	17133026	2	KNOB, M10 STAR HANDLE
22	90336637	2	WHEEL, 3.15OD
23	90513631	1	PIN, THD 90513631

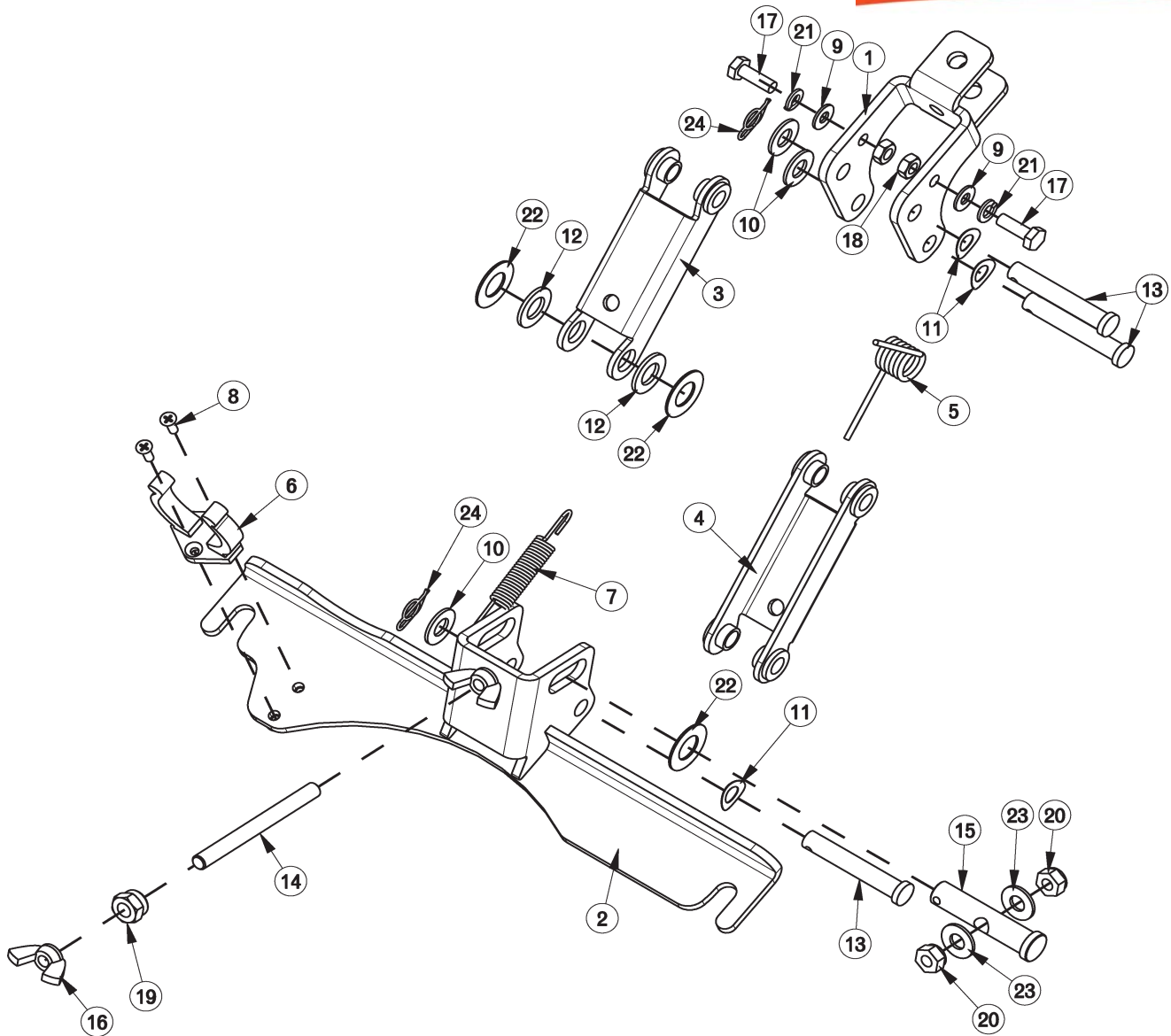

BILL OF MATERIAL - 172150

ITEM	PART NO.	REQ'D	DESCRIPTION	ITEM	PART NO.	REQ'D	DESCRIPTION
1	172134	1	BKT, MAIN SQUEEGEE HINGE	13	711678	3	CLEVIS PIN 3/8 X 2-1/4
2	172155	1	SQUEEGEE MOUNT WMT	14	712147	1	ROD-THD 5/16-18 X 3.5 SS
3	172196	1	SQ TOP LINK W/ BUSHING	15	712148	1	CLEVIS PIN, 1/2 x 2.25 W/ HOLE
4	172197	1	SQ BOT LINK W/ BUSH	16	712157	2	NUT- WING 5/16-18 SS
5	172261	1	TORSION SPRING	17	712562	2	BOLT-HH 1/4-20X3/4 SS
6	260579	1	TOOL CLIP, 1.5" HOSE	18	712665	2	NUT-HEX 1/4-20 SS
7	430051	1	RETURN SPRING-3.00"	19	712680	1	NUT-HEX 5/16-18 SS
8	710530	2	SCR-MC FL HD 8-32 X .50 BRS	20	712683	2	NUT, HEX 5/16-18 NYLOC SS
9	711504	2	WSR-FLAT 1/4 ID SS	21	712758	2	WSR-HELICAL 1/4 SS
10	711515	3	WSR-FLAT .406 X .812 X .0625	22	712760	3	WSR-FLAT .56X1.06X.04 SS
11	711523	3	WSR-WAVE .37X .68 X .08	23	712772	2	WSR-FLAT .344 x .75 x .06 SS
12	711592	2	WSR-FLAT .50 X .9 X .075 NYL	24	3400125	2	PIN-COTTER 3/8 RUE RING

Revision F
Effective November 1, 2008
PowerBoss Made Simple Industrial Limited Warranty

Minuteman International owner of PowerBoss warrants to the original purchaser/user that the product is free from defects in workmanship and materials under normal use. PowerBoss will, at its option, repair or replace without charge, parts that fail under normal use and service when operated and maintained in accordance with the applicable operation and instruction manuals. All warranty claims must be submitted through and approved by factory authorized repair stations.

This warranty does not apply to normal wear, or to items whose life is dependent on their use and care. Parts not manufactured by PowerBoss are covered by and subject to the warranties and/or guarantees of their manufacturers. Please contact Minuteman International for procedures in warranty claims against these manufacture.

Special warning to purchaser – Use of replacement parts not manufactured by PowerBoss or its designated licensees, will void all warranties expressed or implied. A potential health hazard exists without original equipment replacement.

All warranted items become the sole property of Minuteman International or PowerBoss or its original manufacturer, whichever the case may be.

PowerBoss disclaims any implied warranty, including the warranty of merchantability and the warranty of fitness for a particular purpose. PowerBoss assumes no responsibility for any special, incidental or consequential damages.

This limited warranty is applicable only in the U.S.A. and Canada, and is extended only to the original user/purchaser of this product. Customers outside the U.S.A. and Canada should contact their local distributor for export warranty policies. PowerBoss is not responsible for costs or repairs performed by persons other than those specifically authorized by PowerBoss. This warranty does not apply to damage from transportation, alterations by unauthorized persons, misuse or abuse of the equipment, use of non-compatible chemicals, or damage to property, or loss of income due to malfunctions of the product. If a difficulty develops with this machine, you should contact the dealer from whom it was purchased.

This warranty gives you specific legal rights, and you may have other rights, which vary from state to state. Some states do not allow the exclusion or limitation of special, incidental or consequential damages, or limitations on how long an implied warranty lasts, so the above exclusions and limitations may not apply to you.

	Travel*	Labor	Parts	Engine	Extended Warranty	Costs
Walk behinds						
Battery sweepers	Ninety days	One year	One year	N/A	2 years Parts + Labor (or 2000 Hours)	2%
IC sweepers	Ninety days	One year	One year	Through manufacturer	2 years Parts + Labor (or 2000 Hours)	2%
Battery scrubbers	Ninety days	Two years	Three years	N/A	3 Years Parts + Labor (or 3000 Hours)	2%
Riders						
Battery scrubbers	Ninety days	Two years	Three years/2000 hrs	N/A	3 Years Parts + Labor (or 3000 Hours)	2%
IC sweeper/scrubbers	Ninety days	Six months	Two years/2000 hrs	Two years/3000 hrs**	2 years Parts + Labor (or 2000 Hours)	3%
IC sweepers	Ninety days	Six months	Four years/3000 hrs	Five years/3000 hrs**	4 Years Parts + 2 Years Labor (or 4000 Hours)	3%
Exceptions						
Apex series sweeper	Ninety days	One year	One year/1000 hrs	One year/1000 hrs**	2 years Parts + Labor (or 2000 Hours)	3%
6X sweeper	Ninety days	Six months	Two years/2000 hrs	Two years/2000 hours**	2 years Parts + Labor (or 2000 Hours)	3%

Tank Bladders Eight years/ no additional labor
Polypropylene plastic tanks Ten years/ no additional labor
Batteries 0-3 months full replacement, 4-12 prorated credit
Charges One-year replacement
Replacement parts Ninety days

*Two-hour cap

**Through engine manufacture. See section 3 of warranty manual for engine warranty exceptions

***Base upon dealer's certification status

Extended Warranty MUST be signed up within 30 days of delivery to End User (Dealer has 1 Year from Receiving Machine to Sign up extended Warranty)

Extended Warranty Cost is based on Invoice Price multiplied by the Percentage listed in the Extended Warranty Column

All above labor and travel reimbursed at 65 or 75% of the published shop rate.